



END FED 6–40 Meter Multiband HF Antenna

Introduction

This project produces an inexpensive, multiband, end fed HF antenna matchbox that is quick and easy to setup and use. The end fed feature adds convenience, but does present another issue. The problem with an end fed half wave antenna is that the antenna presents a high impedance, creating a significant miss match with the usual transceiver impedance of 50 ohms. This miss match is significantly greater than typical tuners can accommodate without a matching transformer.

This project creates a trifilar wound, 9:1 UNUN (unbalance to unbalance) toroid matching transformer that will match the high input impedance of an end fed antenna into the range where most antenna tuners can produce good performance. The matchbox handles 100 watts of power. *This project requires an antenna tuner to achieve satisfactory SWR.*

The matchbox project uses readily available common hardware and materials. For your convenience, Emergency Amateur Radio Club of Honolulu volunteers make fully assembled matchboxes for those who don't want to construct one. Proceeds support the club and amateur radio. Order information is included on the last page.

Matchbox Parts List

- 1 small plastic enclosure and cover
- 1 powdered iron toroid T106-2 or T130-2
- 3 20" pieces of 22 gauge solid insulated copper wire in red, green, and black
- 2 6-32 x 3/8" machine screws
- 2 #6 lock washer/nut
- 1 10-24 x 3/4" machine screw and lock washer/nut
- 2 #10 flat washers
- 1 #10 lock washer
- 1 #10 wing nut
- 2 #10 wire lugs
- 1 #6 wire lug
- 1 SO-239 panel mount connector
- 1 30' #18 AWG insulated stranded wire antenna
- Few drops of clear PVC adhesive to secure cover in place
- Clear silicone caulk to secure toroid in place

Preparing the MATCHBOX Plastic Enclosure

Start the project by drilling one 5/8" hole and two 9/64" mounting holes for the SO-239 coax connector on the lower side of the enclosure. Use the connector as a guide to mark for accurate drilling of smaller holes. Next, drill a 3/16" hole in the upper right side of the box for mounting the antenna connector.

TOROID WINDING

Next wind the three 20" pieces of insulated solid wire onto the toroid. Place the wires as shown green-black-red, and wrap the toroid 9 turns so that it looks like the photo on the right. Notice there are three wires extending from the left winding and three wires extending from the right winding. As the connections are completed, the steps refer to the specific wires by left or right and color.



Next, trim, crimp together and solder **the left black wire** with the **right red wire**. When the step is completed, it will look like the photo on the right:



The next three steps should appear as shown in the right photo. Crimp and solder a #10 lug to the **left red** wire about 2" from the toroid. The completed lug will later connect to the antenna connection bolt on the top side of the enclosure.

Twist the **left green** wire with the **right black** wire. Strip the ends of the two wires; twist together at about 2". Solder this wire pair to the center connection of the SO-239 connector.

Trim and strip the remaining **right green** wire at about 2". Crimp and solder a #6 lug. This lug will connect through a 6/32 machine screw to the ground of the coax connector.

Next, place the SO-239 through the 5/8" mounting hole from inside the box and position over the two mounting holes. Place a 6/32 x 3/8" machine screw through each mounting hole and connector. Place the #6 lug connected to the green wire over one of the machine screws. Next place a #6 lock washer/nut over both machine screws. Securely tighten both machine screws.

Position the toroid inside the box to allow connection of the red antenna wire lug to the 10-24 machine screw on the upper right box side. Place the 10-24 machine screw through the #10 lug connector on the red wire, followed by a lock washer, then a flat washer, and next insert it through the 3/16" hole in the upper side. Place a flat washer on the outside of the box followed by a #10 lock washer/hex nut. Tighten the nut to hold securely. Next, place the wing nut on the antenna connector and your project appears as shown above.

A small spot of clear silicone caulking compound is used to secure the toroid from movement in the enclosure. The only remaining assembly step is to securely glue the box cover in place with PVC cement.

Preparing the Antenna Wire

Matchbox performance will be determined by two factors: The length of the antenna wire, and the capability of the tuner. The length of the wire should generally be between 22 and 60 feet for best



performance. Longer wires may have excessive impedance for some tuners to properly match. Wires shorter may not radiate as effectively. A 30 foot insulated 18 gauge stranded wire antenna and connecting lug is included with the project and should meet most requirements. Experience has shown that most external tuners and many internal tuners will tune 80–6 meters with an antenna length of 22' to 30'. If a longer antenna is desired, the provided antenna can be lengthened.



Some tuners, in particular internal tuners, may not tune the full 80-6 meter range. You may need to try different wire lengths to optimize your antenna configuration. If you are having difficulty getting your rig to tune, start with a 26' wire. This should produce good results on at least 40-6 meters using the narrowest performance range of internal tuners. Best performance is achieved with a coax of 16' or longer.

Additional counterpoise is not required in this design. The system works well in horizontal, sloper, and vertical configurations.

Observe established safety practices when working with antennas, and avoid proximity to power or utility wires. Permanent installations should be equipped with appropriate static and lighting protection.

Keep amateur radio safe and fun! If you would like to share your experiences with this project, email the club at <http://www.earchi.org>.

Toroid Wiring Schematic

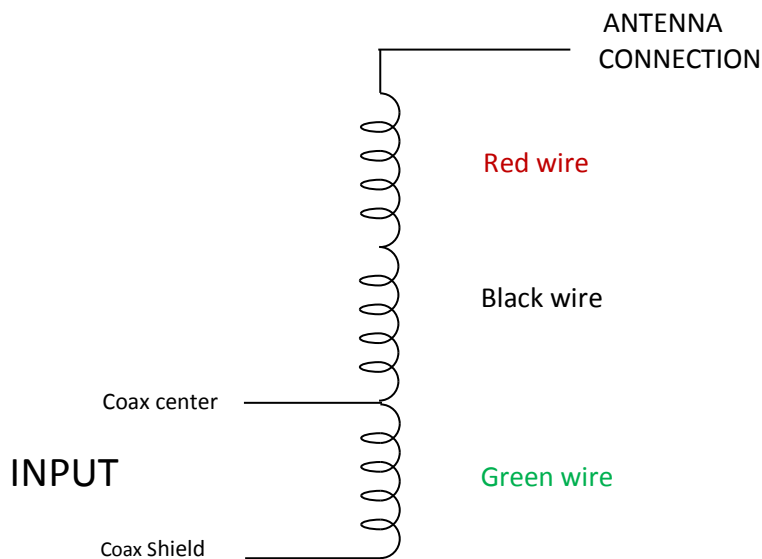

Customer Feedback on EARC 6-40 End Fed Matchbox Antennas

The antenna is amazing. I receive fantastic signal report from DX stations as well as hams around the country. I previously used a short version GR5V that was in an inverted V configuration on the roof of our house. This antenna was noisy but worked. Your antenna out performs the prior antenna and is much quieter. Thanks again for the fine product that your club offers. **May 2012**

It took me 10 minutes to install and WOW - within 10 minutes I made my first HF contact (from CT to GA). And in the span of 4 hours made 3 more !! I was transmitting just 5 Watts from Yaesu 857ND using this antenna. This antenna rocks ! Thanks a ton ! 73 **May 2012**

The 6 - 40 Matchbox antenna works great! Easily tunes with the Z100 tuner - very low SWR's on 20m thru 10m. Antenna was up about 45 feet on tree branch - wire length was about 52.5 feet, slight slope, 55 feet of coax, line isolator at radio. **Work Hawaii for the very first time. Guess the antenna wanted to call home :-)** 57 report, 100 watts, 15 Meter band, Icom 718. A great portable antenna that I will use often at Montrose Harbor along the lakefront in Chicago. Thank you for a fine, well made product. **April 2012**

Not surprisingly I pick up many southern Californian stations. But my joy was my first two DX QSOs; first KD1NA Boston, Mass., on 28.400.0, off the back of the antenna then PY2XC Sau Paulo, Brazil on 28470.0 where we talked for about five minutes. I call that success! **April 2012**

It arrived today in fine shape. I got it up in the air this afternoon using a 31 foot radiator. Top is at 45 feet. Loads on all bands 80-10M with my LDG auto-tuner absolutely no problem, My first QSO was KH7X in the ARRL SS contest with 100W. Amazing. This thing rocks! It's a great antenna! Nice job and a great buy. **November 2011**

I set-up my jackite pole today and tried a 68' wire with the 9:1 unun matchbox. I set it up as an inverted L with about 26 feet vertical and 42 feet horizontal. With my IC-703 it tuned 80 through 6 all well below 1.5:1. I am going to leave the antenna up a few days and make a few contacts. I think the matchbox is terrific. **October 2011**

My 6 – 40 meter end fed arrived through the UK holiday mail and I departed from my norm of a sloper and mounted it vertically on a 10m fishing pole. It is surprisingly effective and rewarded me with a surprise contact on 17m into the Falkland Islands at 20:30UT last night. **January 2012**

When I attached it to a 10m fiberglass fishing pole and went vertical - wow! Easy 5/9 contacts out to 6,000+ miles when propagation was anything better than the worst. My simple ATU easily matches the antenna with SWR never greater than about 1.4 on any band it is built for. **December 2012**

You can dither and procrastinate, but with this antenna, you'll be talking to the world in no time on any band that happens to be hot - and with your hard-earned cash hardly touched! **January 2012**

Just wanted to report back that I have tossed the antenna into a tree about 20' up in an inverted vee shape and I am pleased to report that I can tune anywhere I need on 40-10M using the TS-590 internal tuner!! My first contact was on 40M within 10 minutes of erecting the antenna and was all the way to TX from my condo here in MI using just 10 watts.

This is by far the best HAM related investment I have made in a long time. Living in a condo with strict association rules, I am able to conceal this wire in a tree out my bedroom window and talk all over. I'm very happy and would recommend this antenna to anyone in a similar situation. **March 2013**

I have had your multiband end fed antenna installed here in Singapore for a few weeks now and am very pleased. The order and delivery were painless and well managed as I received my antenna about 2 weeks

following my order which is very good. I used the wire from my previous antenna which is 66 feet long. It works beautifully! I have it hanging vertically outside my 15th story apartment window on a 5 foot horizontal pole (to get it away from the reinforced concrete building). A couple of fish weights on the end keep it from blowing around too much. I would recommend this antenna to anyone who is facing a challenging QTH. **April 2013**

I received my antenna yesterday, a quick 4 days since I ordered it. I attached it to a 31 foot pole and my IC-706MK2. Within minutes, I made my first contact with 9A4KW in Zagreb, Croatia on 20 meters. Being able to reach out over 4,000 miles gives me real confidence that I have found my portable antenna. Thanks for your rapid response and fine product. **May 2013**

I love my End Fed 6 - 40 Meter Matchbox Antenna! I live in an antenna restricted condo and only have a small balcony to place stealth antenna. Fortunately, I live on the 4th floor (top floor) of my condo complex. I put my new antenna up using a Telescopic Fiberglass vertical pole. I use a patio umbrella base to support the pole. I can only go HF after dark; but this is okay. In the past, I have tried several so called stealth antennas and all without success. I purchased the LDG AT-200Pro II Autotuner and was ready to go. I made my first contact within 5 minutes on 40M. Now, I am a happy trooper and can finally work 80 thru 6 Meters successfully. Thanks so much for this great antenna design. **July 2013**

In only 2 weeks of casual on-air time. If you could see how I had to zig-zag it through a big tree above the roof of my RV, you'd be saying like I am, "how the heck can that work? I worked 90% of the stations I called, and just added Mexico City on 15m that gave me a 5x9. **September 2013**

Just wanted to let you know how pleased I am with my ERAC matchbox antenna. I put the ERAC antenna in the backyard with the feed point at 4 feet and the wire sloping up to 35 feet. I have 125 feet of coax feed line. My transceiver's built-in antenna tuner will adjust the SWR to below 1.2 to 1 on all bands 80-6 meters. Last weekend I worked 65 countries on 5 continents. I live in an antenna restricted community and this antenna has allowed me to enjoy ham radio again. **February 2014**

I used the ERAC Matchbox with **BNC** connector today. It works GREAT on 20m with a 31ft radiator in vertical positioning, fed with 25ft of RG175/u coax. I've been talking up and down the east coast with 3W on SSB all afternoon! People ask me to repeat my power output again and again. I can't wait until I get the chance to use it at night, where I think it'll really shine! This has a permanent place in my portable kit. Thanks for the great product! **April 2014**

EARC Antennas are in virtually every state, these countries and more!

Argentina Australia Belgium Brazil Canada Chile Denmark Greece Hong Kong
Ireland Israel Mexico Mozambique New Zealand Singapore Sweden Tasmania United
Kingdom

ORDERING A MATCHBOX ANTENNA FROM EARC

Volunteers at the Honolulu Emergency Amateur Radio Club (EARC) carefully assemble the 6-40 meter End Fed matchbox antenna for those who prefer not to build one. The club will build one for **\$49** including USPS priority mail shipping anywhere in the U.S

BNC Connector Option

If you prefer a **BNC connector** rather than a SO-239 connector on your matchbox, specify "**BNC**" prominently in your order, and we will ship a matchbox with a BNC connector instead of the standard SO-239.

Payment by

To pay via **PayPal**, make your payment to paypal@earchi.org using any major credit card. Include your name and mailing address with the order.

Payment by Check or Money Order

You may pay via check or money order payable to **EARC**, and mailed to our fundraising chairman at:
Charles Hanebuth
1026 Kiiipohaku Way
Honolulu HI 96825-2881

Include your name and mailing address with the order. Include your email address and we will notify when your order has shipped.

International shipments are **\$79** to most locations. Contact chanebuth@yahoo.com for international orders.

We will ship promptly and you will likely receive the order in 7 days or less. If you have any questions about the matchbox or your order, please email Mr. Hanebuth at chanebuth@yahoo.com.

Thank you for your interest in the activities of Honolulu Emergency Amateur Radio Club and amateur radio.



Chuck Hanebuth KH6HNL
Emergency Amateur Radio Club (EARC)
Fundraising Chairman