

NVIS

Near Vertical Incidence Skywave

James Glover - WB5UDE

NVIS, or Near Vertical Incidence Skywave, refers to a radio propagation mode which involves the use of antennas with a very high radiation angle, approaching or reaching 90 degrees (straight up), along with selection of an appropriate frequency below the critical frequency, to establish reliable communications over a radius of 0-200 miles or so, give or take 100 miles.

Although not all radio amateurs have heard the term NVIS, many have used that mode when making nearby contacts on 160 meters or 80 meters at night, or 80 meters or 40 meters during the day. They may have thought of these nearby contacts as necessarily involving the use of ground wave propagation, but many such contacts involve no ground wave signal at all, or, if the ground wave signal is involved, it may hinder, instead of help.

Deliberate exploitation of NVIS is best achieved using antenna installations which achieve some balance between minimizing ground wave (low takeoff angle) radiation, and maximizing near vertical incidence skywave (very high takeoff angle) radiation. As hams, we often faithfully follow the advice: get your antenna up as high as you can get it! We do this, and other things (like choosing antennas that have a low angle of radiation) in order to maximize the distance over which we can communicate.

An antenna with a particularly high angle of radiation is often somewhat disparagingly referred to as a "cloud warmer", the implication being that if the signal isn't radiated at a low enough angle, it's being wasted.

For NVIS, we ignore all this traditional advice, and select instead techniques which will maximize not our DX, but our ability to reliably communicate with other stations within a radius of 0-300 miles.

Not just any old frequency will work for NVIS. Successful NVIS work depends on being able to select, or find (through trial and error), a frequency which will be reflected from the ionosphere even when the angle of radiation is nearly vertical. These frequencies usually are in the range of 2-10 MHz, though sometimes the limit is higher.

The trick is to select a frequency which is below the current critical frequency (the highest frequency which the F layer will reflect at a maximum--90 degree--angle of incidence) but not so far below the critical frequency that the D and/or E layers mess things up too much.

There are two main types of propagation at HF known as "ground wave" and "skywave".

Ground wave propagation occurs when the receiving station is sufficiently close to the transmitting station, and is able to receive the portion of the transmitting station's signal which clings to the ground. The range of ground wave propagation varies with the type of antenna at the transmitting station, the characteristics of the ground between the transmitting station and the receiving station, and other factors. It can be anywhere from a few miles, to a few dozen miles.

Distances beyond the range of the ground wave signal are covered by skywaves. Skywaves are the waves which radiate upward at some angle from the antenna, and (we hope) are reflected from the ionosphere, to return to earth further away.

The ionosphere is a high altitude region of the Earth's atmosphere which is composed of gaseous atoms which have broken into ions. The sun is the source of the ionizing energy, so the condition of the ionosphere varies with time of day, season of the year, the 11-year sunspot cycle, and the 27-day rotation of the sun.

The layers of the atmosphere that effect radio propagation are the D, E, and F layers. It is the F layer which is usually involved in reflecting our signals back to earth, while the D layer absorbs our signals. The E-layer can either help, or hinder.

Long distance propagation of radio waves is usually achieved by their being reflected from the ionosphere, and returning to earth some distance away from their point of origin. Radio waves which have been radiated at a very low angle of radiation travel a long way before finally making it up to the ionosphere, strike the ionosphere at a very shallow angle (A) and return to earth far away from their point of origin (A').

As the angle of radiation goes up, the radio waves strike the atmosphere at a more moderate angle (B), and return to earth closer to their point of origin (B'). For any given frequency and current state of the ionosphere, there may be some maximum angle of incidence at which the ionosphere will reflect signals back to earth.

Signals which strike the ionosphere at a higher angle of incidence than the current maximum will not be reflected at all, but will continue on out into space instead (C). The area of the earth to which the reflection would have occurred will be in what we call the "skip zone" (unless it's close enough to the signal source to receive the ground wave signal). The skip zone is the region consisting of areas of the earth's surface which are outside the radius the transmitting station's ground wave will reach, and yet not far enough away to receive reflections of skywaves.

NVIS techniques concentrate on the areas which are often in the skip zone. The idea is to radiate a signal at a frequency which is below the critical frequency, at a nearly vertical angle, and have that signal reflected from the ionosphere at a very high angle of incidence, returning to the earth at a relatively nearby location.

No antenna radiates all its signal at exactly one angle, so the best we can get is a range of angles, ranging from perfectly vertical, to nearly vertical.

The portion of the signal which is radiated at a vertical, or nearly vertical, angle reflects back to earth over some radius, which is determined by the lowest angle at which the antenna radiates much signal. Absorption by the D layer, and other factors, determine some minimum frequency below which the signal will no longer be usable, and usually some distance beyond which signals will no longer be usable.

For areas which are within the ground wave range of the transmitting station, the ground wave's presence may interfere with the reflecting skywave. It may very well help, too. It all depends on whether the ground wave and the skywave arrive in phase, out of phase, or somewhere in between, and their relative strengths.

If the ground wave arrives at about the same strength as the skywave, and the two are out of phase, the signal will disappear. Since the height of the ionosphere varies with time, phase alignment may drift from in phase, to out of phase, resulting in signal fading. For this reason, it is best to minimize ground wave radiation when using NVIS techniques, so that it will be less likely to interfere with the skywave.

Although this discussion has focused mainly on the transmission of signals, there is a corresponding advantage of using NVIS techniques in reception, and a trick or two that are useful mainly for reception. The corresponding advantage is that if your antenna favors high angles for transmission, it will also favor high angles for reception. An antenna optimized for radiating at the high angles used for NVIS will also be optimized for receiving the skywaves which will be arriving at a high angle from the ionosphere.

An antenna which does not radiate much ground wave signal will also probably not receive ground wave signals as strongly. When both stations are using antennas which are optimized for NVIS, the mode is favored both in transmission and reception, and those advantages add together, increasing the chances of reliable communication.

There is also an advantage inherent in the use of NVIS style antennas which applies only to receiving. The frequencies which are useful for NVIS (usually 2-10 MHz) are the same frequencies which are most susceptible to atmospheric noise. A major source of atmospheric noise is distant thunderstorms. Nearby thunderstorms are the worst, of course, but the noise from all possible sources adds together. Unless there is a nearby thunderstorm, most noise will be the sum of the noise from distant sources which are all propagated to the receiving antenna.

Since an antenna optimized for NVIS is listening mostly to signals propagated from relatively nearby areas, and does not favor the reception of signals, static crashes, and other sources of noise and interference from more distant sources, it will not hear as much noise or interference as an antenna optimized for DX operation. The result is a better signal/noise ratio.

Taking measures which optimize a station's NVIS capabilities will drop the noise level substantially. Sometimes, the drop in noise can be maximized at the expense of some signal strength, and result in a communication circuit which has lower signal levels, but even more dramatically lower noise levels, for an even better signal/noise ratio than could be achieved by focusing only on maximizing signal levels.

Selecting a frequency below the critical frequency, but not too far below it, and selecting an antenna which will radiate skywaves at a high angle, and minimize ground waves and the reception of noise, are the essential tricks of establishing reliable communication in the 0-200 mile radius which is so often a challenge for HF operation.

Advantages of NVIS

- NVIS covers the area which is normally in the skip zone, that is, which is normally too far away to receive groundwave signals, but not yet far enough away to receive skywaves reflected from the ionosphere.
- NVIS requires no infrastructure such as repeaters or satellites. Two stations employing NVIS techniques can establish reliable communications without the support of any third party.
- Pure NVIS propagation is relatively free from fading.
- Antennas optimized for NVIS are usually low. Simple dipoles work very well. A good NVIS antenna can be erected easily, in a short amount of time, by a small team (or just one person).
- Low areas and valleys are no problem for NVIS propagation.
- The path to and from the ionosphere is short and direct, resulting in lower path losses due to factors such as absorption by the D layer.
- NVIS techniques can dramatically reduce noise and interference, resulting in an improved signal/noise ratio.
- With its improved signal/noise ratio and low path loss, NVIS works well with low power.

Disadvantages of NVIS:

- For best results, both stations should be optimized for NVIS operation. If one station's antenna emphasizes ground wave propagation, while another's emphasizes NVIS propagation, the results may be poor. Some stations do have antennas which are good for NVIS (such as relatively low dipoles) but many do not.
- NVIS does not work on all HF frequencies. Care must be exercised to pick an appropriate frequency, and the frequencies which are best for NVIS are the frequencies where atmospheric noise is a problem, antenna lengths are long, and bandwidths are relatively small for digital transmissions.
- Due to differences between daytime and nighttime propagation, a minimum of two different frequencies must be used to ensure reliable around-the-clock communications.

Dipole as NVIS

Once again, the dependable dipole antenna proves itself useful. One of the most effective antennas for NVIS is a dipole positioned from .1 to .25 wavelengths (or lower) above ground. When a dipole is brought very close to ground, some interesting things happen.

The most interesting thing, from an NVIS perspective, is that the angle of radiation goes up. In the range of .1 to .25 wavelengths above ground, vertical and nearly vertical radiation reaches a maximum, at the expense of lower angle radiation (which we'd like to minimize, anyway, for NVIS).

A dipole can be used at even lower heights, resulting in some loss of vertical gain, but often, a more substantial reduction in noise and interference from distant regions. Heights of 5 to 10 feet above ground are not unusual for NVIS setups, and some people use dipoles as low as two feet high with good results (relatively weak signals, but a very low noise floor).

Another interesting thing that happens with very low dipoles is that their feedpoint impedance goes down. An acceptable SWR with 50 ohm coax is likely. Plan to bring your tuner along just in case, but you may get by just fine without it.

Yet another fortunate thing about low dipoles is that they are easily erected. Finding a tree which will serve as a support is often easy, and it's not hard to get a line in a branch which will suffice. Masts made of PVC tubing are practical at these heights. Very low dipoles can be supported by traffic cones with a notch cut in the top, or a simple tripod made from short sections of PVC pipe or wooden dowels, and bungee cords.

With the exception of the very lowest dipoles, most dipoles will gain an extra 2 db or so of vertical gain if you allow the center to droop a few feet. Allowing the center to droop means that the end supports don't have to be as sturdy, which makes installing a good NVIS dipole that much easier.

Inverted Vee as NVIS

The dipole's close cousin, the inverted vee, is another good NVIS antenna, which can be even simpler to support. An inverted vee will work almost as well as a dipole suspended from a slightly lower height than the apex of the inverted vee, so long as the apex angle is kept gentle--about 120 degrees or greater. An inverted vee is often easier to erect than a dipole, since it requires only one support above ground level, in the center.

Counterpoises

The high angle radiation of a dipole (or inverted vee) can be enhanced by adding a counterpoise wire below it, about 5% longer than the main radiating element, to act as a reflector. The optimum height for such a counterpoise is about .15 wavelengths below the main radiating element, but when the antenna is too low to allow for that, a counterpoise laid on the ground below the antenna is still effective.

A knife switch at the center point of the counterpoise can be used to effectively eliminate the counterpoise from the antenna system. This technique is useful for using a dipole for

NVIS and longer distances, too. A counterpoise is installed at ground level, or as high as the switch can easily be reached, and a dipole is mounted .15 wavelengths above the counterpoise. When the switch is closed, the vertical gain will increase, and the noise levels will drop. When the switch is open, lower angle gain will increase, improving the antenna's performance for non-NVIS use.

Frequency selection for NVIS operation

The selection of a optimum frequency for NVIS operation depends upon many variables. Among the many variables are time of day, time of year, sunspot activity, type of antenna used, atmospheric noise, and atmospheric absorption. To select a frequency to try, one may use recent experience on the air, trial and error (with some sort of coordination scheme agreed upon in advance), propagation prediction software, near real-time propagation charts (available on the Internet) showing current critical frequency, or even just a good educated guess.

Whatever the strategy used for frequency selection, it would probably be best to be prepared with some sort of "Plan B" involving communicating through alternate channels, or following some pre-arranged scheme for trying all available frequency choices in a scheduled pattern of some sort.

The information for this drawing was taken from an article by Dr. Carl O. Jelinek.

Dr. Jelinek used two sections of 1 1/2-inch PVC pipe for a mast. If you have the room to install this type antenna, it may very well be the ideal antenna for Regional MARS communications.

It is supposed to work the Skip Zone out to about 1000 miles. It is not a DX type antenna and the power is limited to around 200 watts. You will also need an antenna tuner in order to get a good match.

Jim Richard - AAR6CR has been experimenting with the antenna and may be of some assistance to those members that would like to learn more. This style of antenna has long been used for local communications by the military.

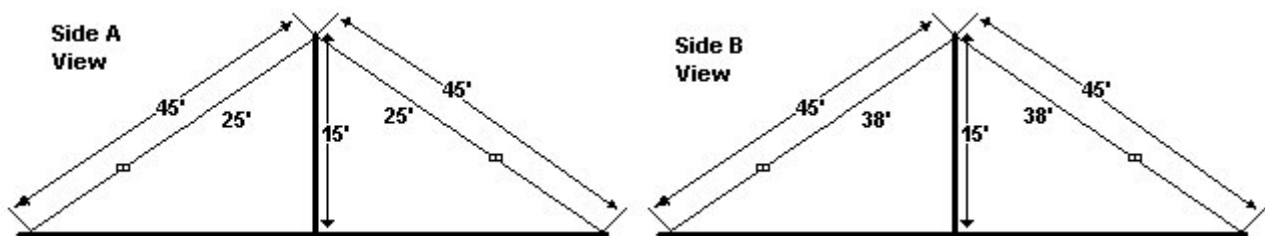

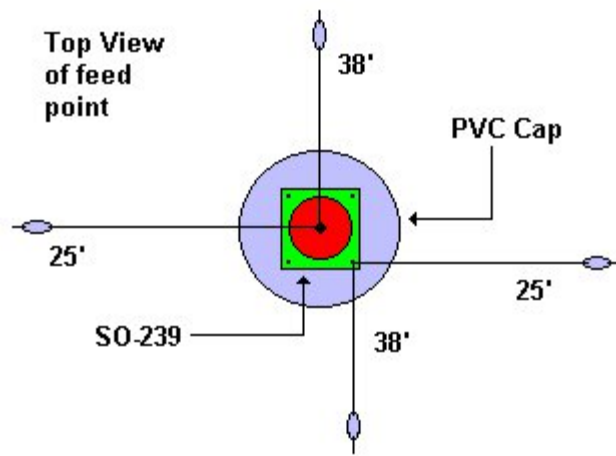

NVIS Tri-Band Antenna for 75, 60, & 40 Meters

